

15k-20k psi Powered Cleaners

SG-40™ & SG-50™

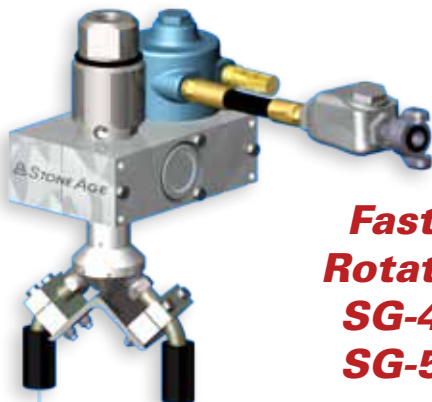

**Faster
Rotation
SG-40™
SG-50™**

Shown with optional
2-port head assembly.



The **SG-40™ & SG-50™** are fast rotation tools, belt driven to operate at 250 rpm-1,000 rpm. The **SG-40™** uses an air motor and the **SG-50™** a hydraulic motor. In the photograph above an **SG-40™** cleans a tube bundle.

SG-40™ Air-Powered SG-50™ Hydraulic

SG 40™ & 50™	15k psi (1000 bar)	20k psi (1400 bar)
Swivel	SG-CCN-P12K™	SG-CCN-M12K™
Flow Capacity	50 gpm 190 lpm	50 gpm 190 lpm
Flow Rating	2.3 Cv	2.0 Cv
Rotation	250-1000 rpm	250-1000 rpm
Inlet Port	3/4 npt	3/4 MP*
Outlet Shaft	1-1/8 in. K**	1-1/8 in. K**
Air Sup @ 80psi	40 CFM 20 l/sec	40 CFM 20 l/sec
Hydraulic Sup.	2k psi @ 4 gpm	2k psi @ 4 gpm
Weight	26 lbs 11.8 kg	26 lbs 11.8 kg

* Medium pressure cone & thread. **1 1/8 in. OD O-ring.

SG-E60™

SG-E70™

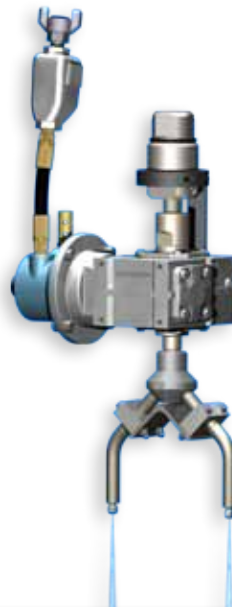

**Slower
Rotation
SG-E60™
SG-E70™**

Shown with optional
2-port head assembly.



The **SG-E60™ & SG-E70™** also feature powered rotation, but at much slower speeds. The two options are 10 rpm-50 rpm, and 80 rpm-500 rpm. Slower rotation speeds increase dwell time and depth of penetration which has been proven to aid removal of thick deposits, particularly at long standoff distances. The **SG-E60™** is air-powered and the **SG-E70™** uses a hydraulic motor.

SG-E60™ Air-Powered SG-E70™ Hydraulic

SG E60™ & E70™	15k psi (1000 bar)	20k psi (1400 bar)
Swivel	SG-P12KM™	SG-M12KM™
Flow Capacity	110 gpm 420 lpm	110 gpm 420 lpm
Flow Rating	4.6 Cv	4.6 Cv
Rotation	10-50 or 80-500 rpm	10-50 or 80-500 rpm
Inlet Port	3/4 npt	3/4 MP*
Outlet Shaft	1-1/8 in. K**	1-1/8 in. K**
Air Sup. @ 80psi	40 CFM 20 l/sec	40 CFM 20 l/sec
Hydraulic Sup.	2k psi @ 4 gpm	2k psi @ 4 gpm
Weight	30 lbs 18.1 kg	30 lbs 18.1 kg

* Medium pressure cone & thread. **1 1/8 in. OD O-ring.

SURFACE PREP



www.advancedpressuresystems.com
Toll Free in North America:
1 (877) 290-4277 or (281) 290-9950



40k Air-Powered Cleaners

UH-40™ & UH-50™

UH-40™ Air with Bar Head

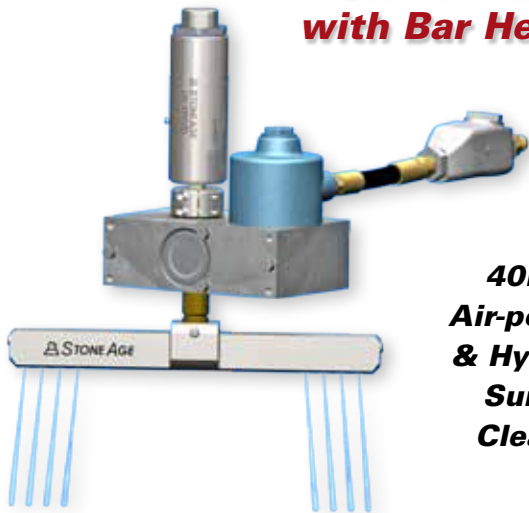

**40k psi
Air-powered
& Hydraulic
Surface
Cleaners**



40k psi with 4-arm assembly.

Powered Rotation to 40k psi

The **UH-40™ & UH-50™ Series** features the reliable **StoneAge® UH-H9G12 Swivel** and belt drive system for thorough and productive surface cleaning. Replaceable sapphire jets provide hard hitting power for epoxy coating removal or other surface preparations. The **UH-40™** uses an air motor and the **UH-50™** a hydraulic drive. Additional options include a 4-arm jet assembly with up to a 20" jet path or the bar head configuration which gives a 14" jet path. Both feature a rugged, high flow design, an optional 90° inlet and use **3/8" OS6 Sapphire** nozzle tips.

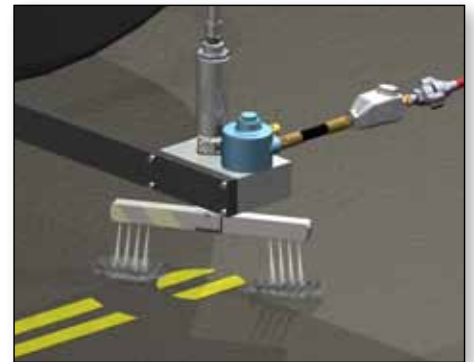

Airport runway paint removal.

UH-50™ Hydraulic with 4 Arm Assembly

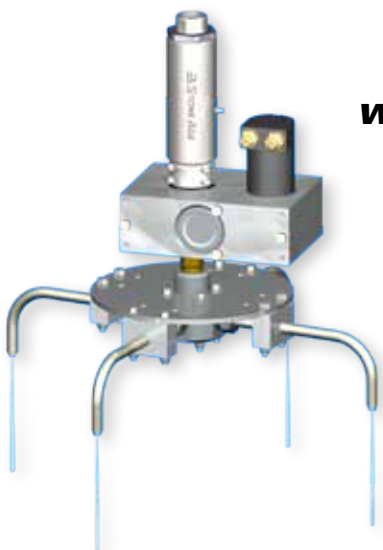

- Clean belts, screens & conveyors
- Remove epoxy coatings
- Clean paint line carriers
- Prepare surfaces for coatings
- Build custom cleaning systems
- Get results with minimum water flow
- More efficient than hand-held methods
- Optional 90° inlet

UH-40™ Air-Powered UH-50™ Hydraulic

Pressure	40k psi (2800 bar)
Swivel	UH-H9G12™
Flow Capacity	20 gpm 80 lpm
Flow Rating	0.50 Cv
Rotation Speed	250-1000 rpm
Inlet Port	9/16 HP*
Outlet Shaft	9/16 HP*
Air Supply @ 80psi	40 CFM 20 l/sec
Weight	26 lbs 11.8 kg

* High pressure cone & thread.



www.advancedpressuresystems.com
Toll Free in North America:
1 (877) 290-4277 or (281) 290-9950

